

CHILDREN'S BOOK WEEK 2023

read
grow
inspire



Activity
Book

QPRC



Libraries

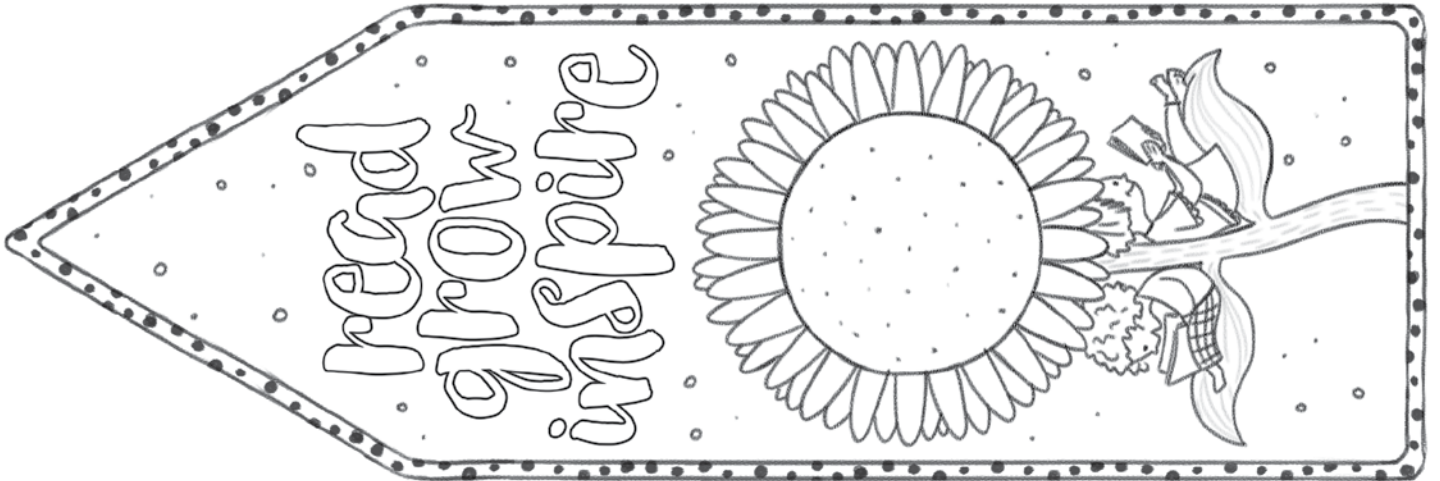

Cut out to make bunting for your Book Week display.

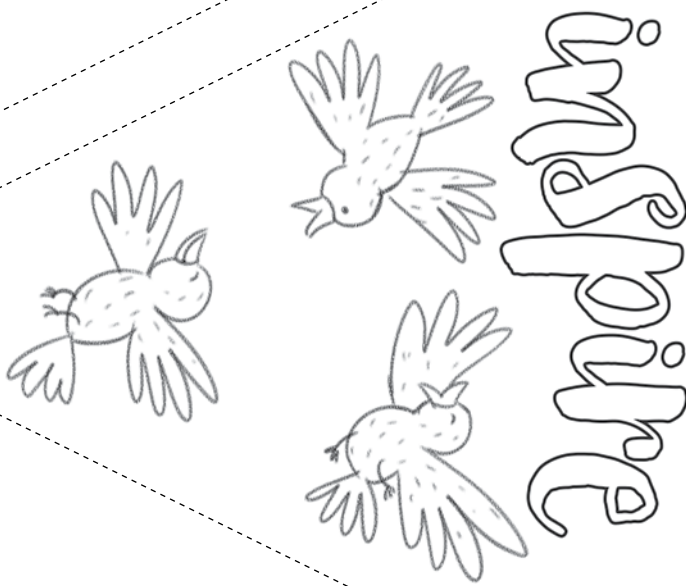
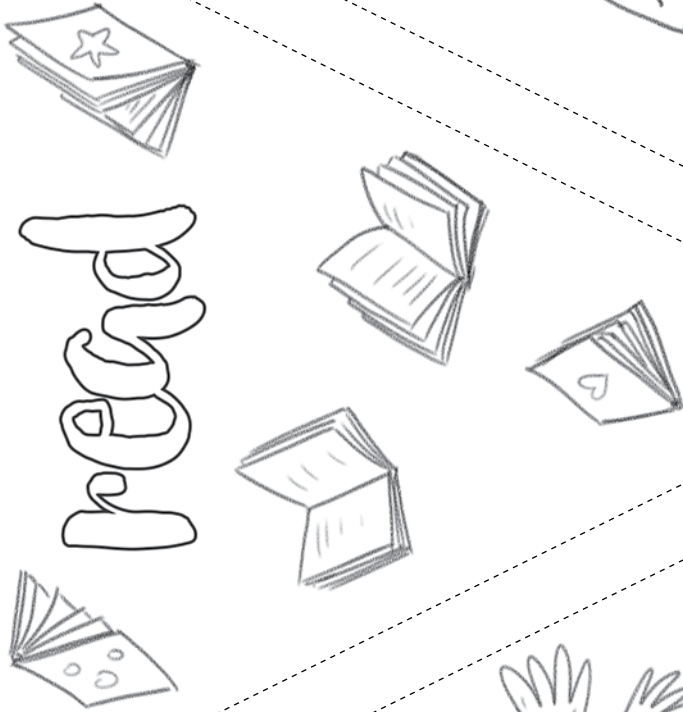
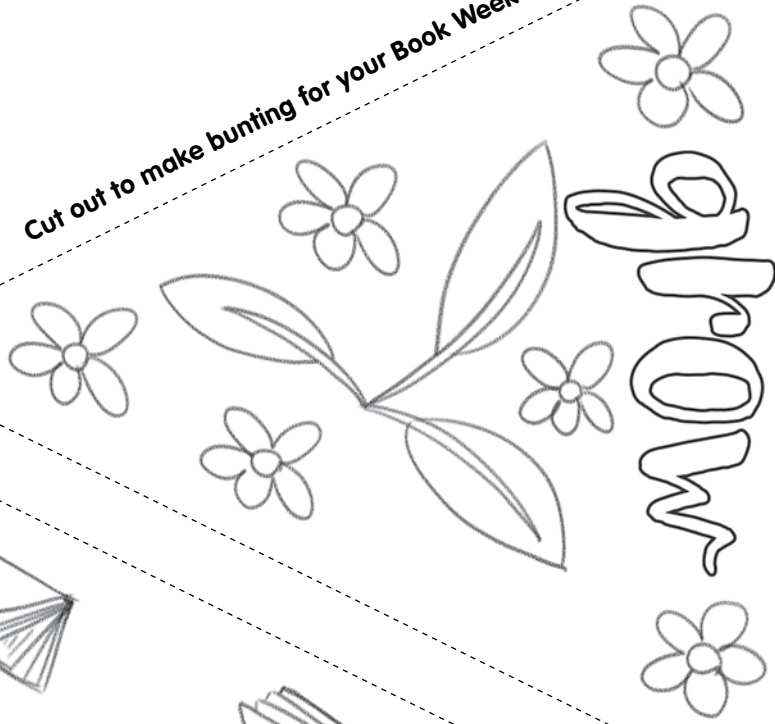

read
grow
inspire





read
grow
inspire

CRITICAL CLUES

Name the shortlisted books these clues lead you to

This one is a bit of a puzzle

A very strange bird

Let's go shopping

Watch out, it will get you

Tall and short friends

In the beginning life was perfect

Nearly from the national anthem

An old, deserted house

A knitting penguin

A story of enchantment

This is our path

Bonsai people

I am, you are ...

Nature in the city

Coming ready or not

Morning to night

Dandelion magic

Time to dress up for Book Week

Black birds and bog people

Friends make a bucket list

A small, clever dog with a phobia

Cherish the moments in between struggles

Shipwrecked animals

Life is more than a concrete floor

Alphabetical under the sea

Migration

You need to know this

Hidden away

Bird bullies

Untamed native animals

Name Class

Make a Mini Book

Instructions

Search inside the shortlisted books to find the facts and judge the books.

There are different styles of mini books but they all fold the same way.

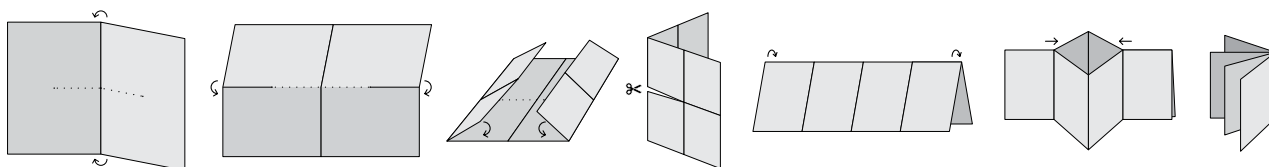

To see a video showing how to fold the mini books, and to print out a set of instructions, use the links below:



Video Instructions
bit.ly/MBookVideo



How to Fold – PDF
bit.ly/FoldMBook

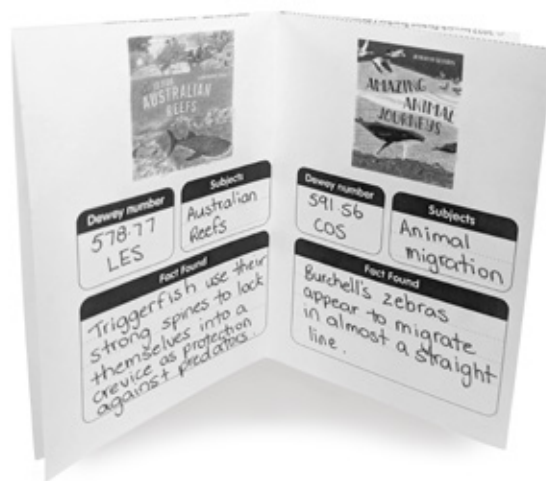

To Use the Mini Books for Early Childhood, Picture Books and New Illustrator

- 1 Print one mini book per student.
Enlarge to A3 to create a bigger book.
For best result, print 'Actual size' – **do not select 'Fit on Paper'**.
- 2 Students write their name on the mini book.
- 3 Print the instruction sheet.
- 4 Show the video.
- 5 Fold, cut and create the book. (Younger students may need more assistance).
 - Show the covers of all books for one category.
 - Children colour the dot for the cover of the book they think looks most appealing to them.
 - Read the blurb on the back of each book.
 - Children colour the dot for the blurb of the book they think sounds most appealing to them.
 - As each book is read over a period of time, children rate each title 1–10.
 - After all books have been read, look at cover, blurb and rating to try to predict which book might be the winner.

To Use the Mini Books for Younger Reader and Eve Pownall Award Categories

- ▶ Repeat actions 1–5 above.
- Discuss criteria for judging each category as listed on the mini book.
- Break class into six groups and give each group one title.
- Follow the directions on the mini book.
- Rotate titles around the groups during the allocated time to complete the mini book.



Colourful Characters

Based on **Frank's Red Hat** by Sean E Avery



In a world where everything seems to be black and white, a little penguin is not afraid to try new things and bring some colour to his community. Inspired by the double-page spread where Frank carries a pile of hats in the most wonderful of colours, make personalised gift tags to celebrate the uniqueness of the people around you.

Use the template to create some tags on card. On one side, write a kind word or words to describe the personality of whoever you are gifting your creation to.

On the other side, decorate your tag with colourful paper, felt, bits of fabric and small objects such as stickers, buttons, feathers and leaves.

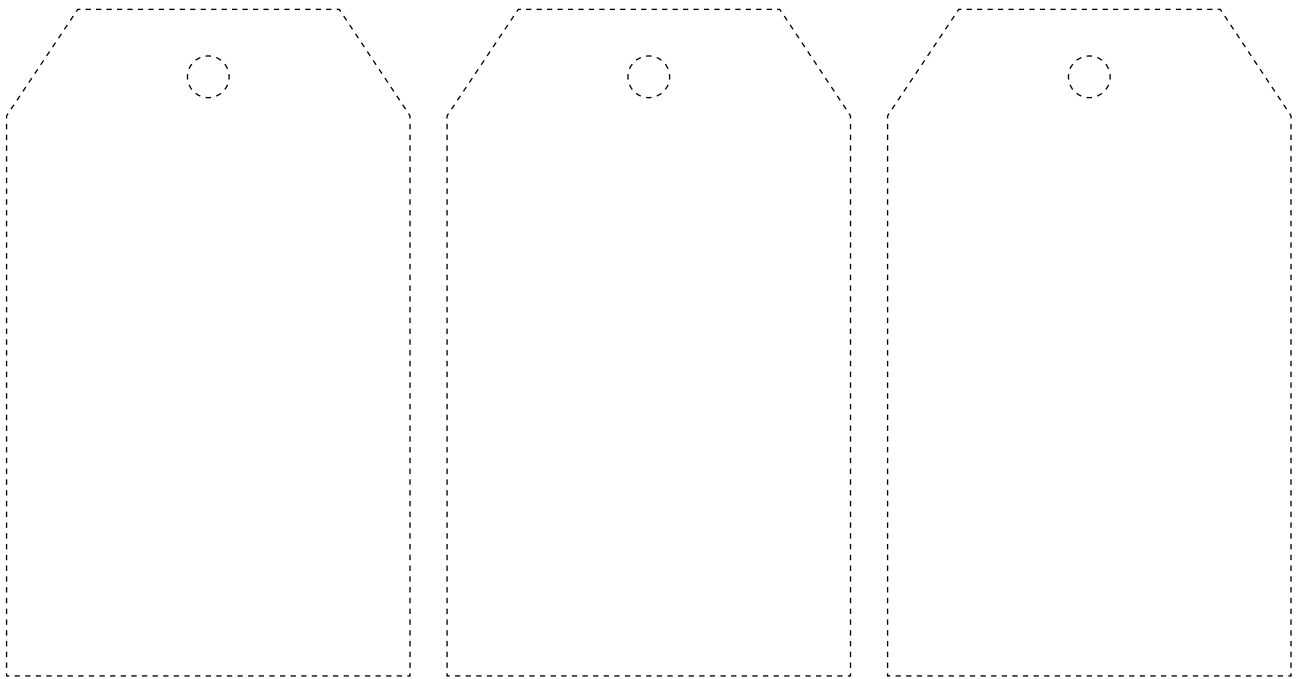

Home is Where the Heart is!

Based on *My Strange Shrinking Parents* by Zeno Sworder

In *My Strange Shrinking Parents*, Sworder makes beautiful reference to the heart of a home, and how over a life span this space changes as a family grows and ages. He also brings to the fore the art of the handmade, and how the act of hand-making and gifting to others is deeply connected to the caring heart. In this art activity, these two significant threads are explored by the making of a home for someone you care about.

Design Brief

Home is a place that is a foundation for love, warmth and happy memories. Make a little house. Using the blackline master as a starting point, design and craft a home for a very special person in your life.

Give the home to them, along with a card of care that states: Home is Where the Heart is!

Materials

- Photocopy of blackline master of house, upper floor and roof on to 300gsm white cardboard
- Black pen – fine-tipped and waterproof
- Watercolour paints
- Watercolour brush
- Water pot
- Scissors
- Tape
- Glue stick
- Cartridge paper





Home is Where the Heart is!



Based on *My Strange Shrinking Parents* by Zeno Sworder

How to Make

1. Brainstorm the key features of a home that connects to caring for your special person.
2. This house needs to be made in 2D and 3D. Look at the template and identify the spaces on which you can create. Identify the ground and upper floor levels, windows, door locations and roof.
3. Draw on a piece of cartridge paper a house plan with details of each room that you will make, including 3D pop-up features.
4. Use a fine-tipped black pen to add details to the rooms, then add colour using watercolour paints.
5. Repeat this process for the roof and upper floor templates.
6. Cut, fold and assemble the house and secure with tape. Fold the flaps of the upper floor and attach to each wall to form the upper floor of the house.
7. Cut, fold and assemble the roof and attach it to the outside wall of the house.
8. Use off-cuts of cardboard to create small 3D pop-ups that include a tab for attachment. Draw with black fine-tipped pen. Colour using watercolours and then cut out. Fold the tab, glue to the structure and reinforce with sticky tape.
9. Present their house with a card titled Home is Where the Heart is!

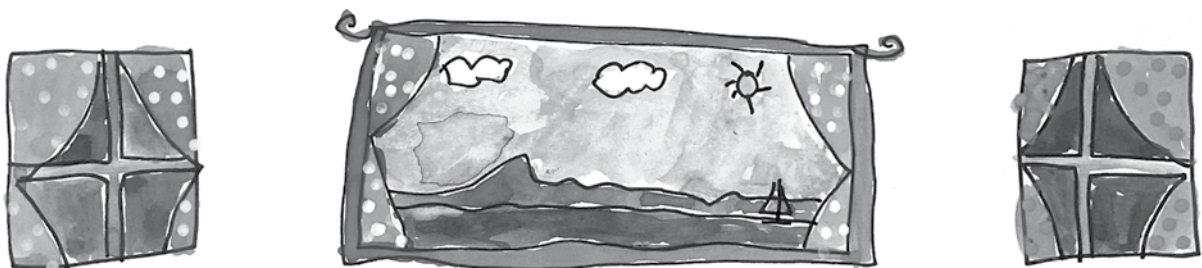
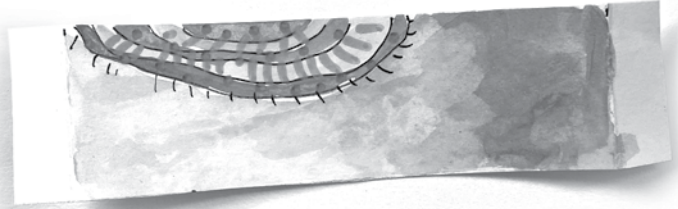

Some Other Ideas

- ▶ Use the same template but alter the materials to include collage, felt pens, and coloured pencil.
- ▶ Use photocopy box lids to create individual rooms. When complete, connect each lid together to make towers of units. Add a roof for a class collaboration.
- ▶ Look at doll houses for ideas.



----- Cut Line
 - - - - - Fold Line

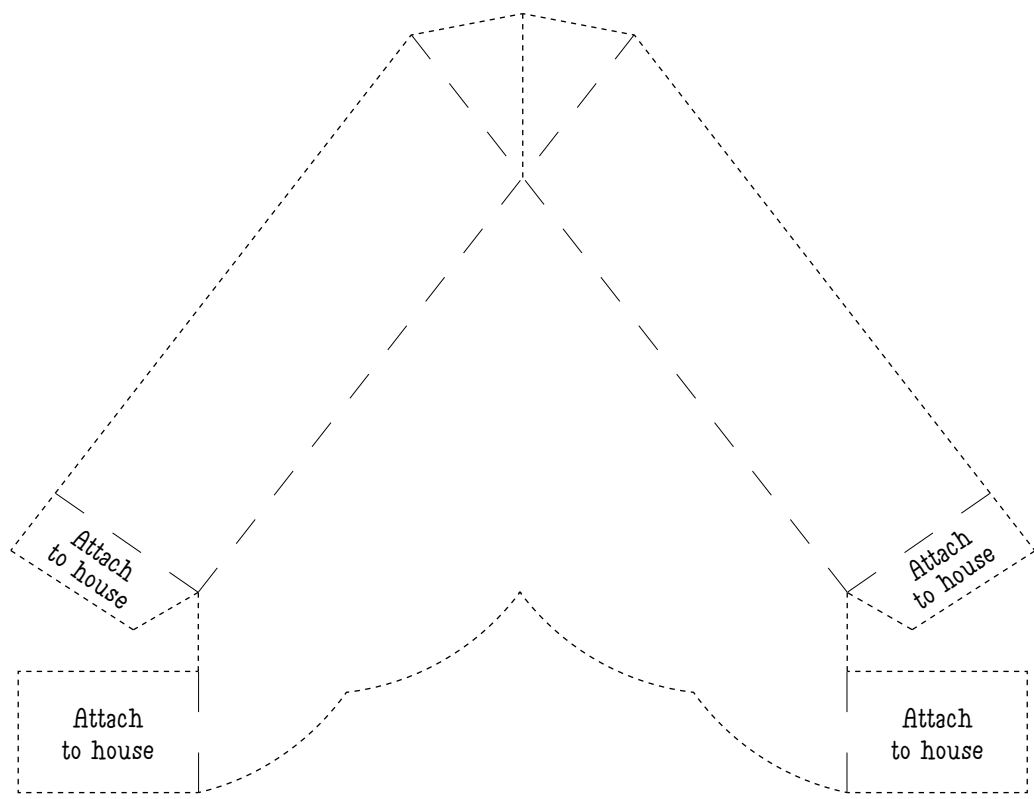
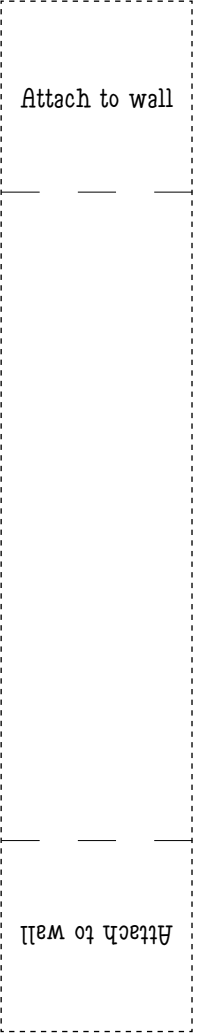



Potato Print Wallpaper



Based on **Farmhouse** by *Sophie Blackall*

Design a farmhouse and decorate it with your own wallpaper using carved potatoes, like the twelve children in the story did long ago. Use a pre-carved potato supplied by the teacher or make your own.

Materials

- Half a potato for carving and printing (or a pre-carved potato)
- Acrylic paint
- Coloured marker pens
- Green A3 card for backing
- Black A4 card for house frame and white for potato prints
- A4 paper for making the chain of children
- Corrugated or textured card for the roof



- ▶ Carve the potato to leave a raised circle on the top, then use it to create the flower head patterns for the wallpaper by dipping it in the paint and pressing it onto the A4 card. Use a few different colours to make the wallpaper colourful. When the paint dries, draw the leaves on with a marking pen. Using different coloured marking pens, draw a spiral at the top of the circle to create the flower design.
- ▶ Create a four-pane window using black A4 card. Mark it into four rectangles, leaving a wide enough border for the frames. Cut out three of the rectangles for the windows. On one bottom rectangle only cut three sides to make the door. Design the front door on different coloured card, using a button for the door handle, and create a keyhole. Glue onto the door. Cut a triangle from the corrugated or textured card to make the roof, and a rectangle to make the chimney.
- ▶ When your wallpaper is complete, paste it onto the green A3 backing card. Overlay the window and door frame over the wallpaper. Glue the roof and chimney on top.
- ▶ To make the paper chain of children, fold a strip of paper back and forth like a concertina. Draw a figure on the top layer with the hands reaching right to the sides. Cut out the figure but be careful not to cut around the hands or the children will not be joined together. Using the coloured markers, colour in the children's clothes. Pose and arrange the children where you would like them placed.
- ▶ Finally, use some of the card to create the cat that the children coloured long ago as they decorated their walls, and then place it in one of the windows.

Yanay Daore!

Based on **Our Dreaming** by Kirli Saunders and Dub Leffler

Dub Leffler has walked the earth to see the plants and animals and then share his observations with us through his art. He has used watercolour and coloured pencils as his medium. On the double-page spread showing the echidnas and what is under the earth, Dub has sprinkled salt on the wet watercolour paint to remove some of the colour and create the blotchy effect. Discover your own place.

Go for a nature walk.

- ▶ Take notice of the natural objects. Consider the different colours, textures and sizes.
- ▶ Collect your favourite object (but only those that have already fallen or are not alive). Never take the last one. Leave enough for nature to replenish.

Gather some art supplies.

- Pencils, pens, crayons, watercolour paint, food ink
- A4 paper

Practise drawing the object you collected.
Fold your A4 paper into quarters.

- ▶ In square one, draw your object without lifting the pencil off the page.
- ▶ In square two, draw your object from a new perspective.
- ▶ In square three, draw it again in pen.
- ▶ In square four, experiment by adding thickness to some lines and shapes.
- ▶ On a new A4 page, redraw your object adding texture into the shapes with dots or cross-hatching.

Illustrate your final drawing. First look at the end pages where Dub has used a variety of mediums as inspiration, or use food or plant ink (prepared by your teacher).

- ▶ Pour 1/2 cup boiling water over 4 tea bags. Steep for about 15 minutes. Squeeze as much tea (tannin) as possible from the teabags. Stir in 1 teaspoon of gum arabic and mix until you have a consistent solution. Strain the ink so that you are left with a thick paste and allow it to cool before bottling it.
- ▶ Try some other foods e.g. coffee grounds, beetroot, onion, onion skins
- Another way to make food 'ink' – Mix 1 cup of distilled water, 1/2 tablespoon of bicarbonate soda and 1 tablespoon of grated food.
- Other ideas for ink. bit.ly/Plant-Ink



New Pup

Based on **Lionel and Me** by Corinne Fenton and Tracie Grimwood



Write the missing word in the sentence.

Maverick was a big

kennel

Lionel's legs were so

short

Maverick ate Lionel's

meal

The children went on long

dog

Maverick was lonely

monkey

Lionel tore the arm off the

outside

Maverick and Lionel slept in the

walks

In the book **Lionel and Me**, the children have drawn pictures of their pet to hang on the wall. On another piece of paper, draw a portrait of your pet. If you don't have a pet, then draw your own picture of Lionel and Maverick.

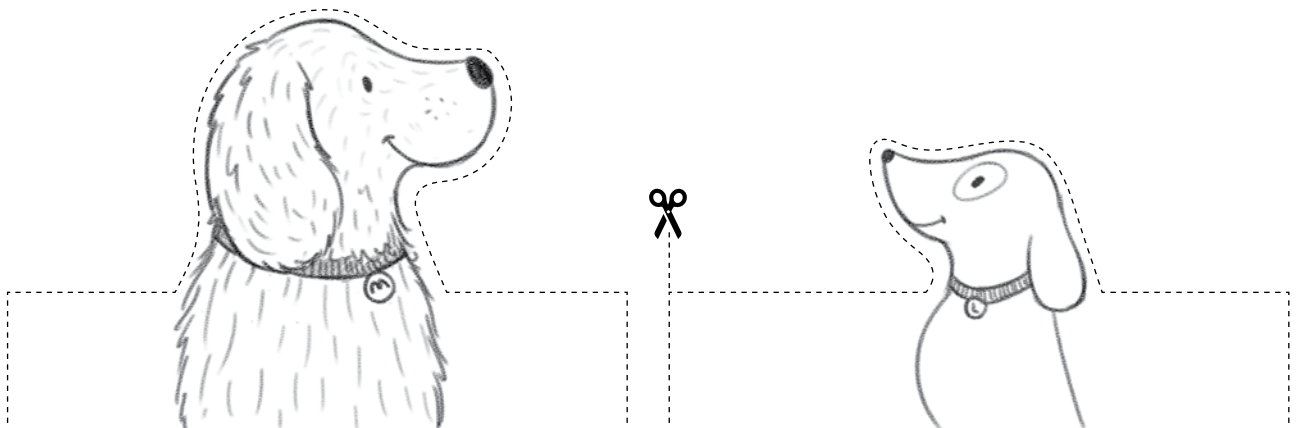

Colour the finger puppets and cut them out.

Find a partner. Use the finger puppets to pretend you are Lionel or Maverick. If you are Maverick, talk to Lionel and tell him how you are feeling about the things he does. If you are Lionel, talk to Maverick and tell him what you are thinking and how you feel.



Jigsaw Creator



Based on **Jigsaw: A Puzzle in the Post** by Bob Graham

In **Jigsaw: A Puzzle in the Post** by Bob Graham, the Kelly family work together to make a puzzle of an African sunrise.

Instructions

- ▶ Draw your own African sunrise or whatever drawing you would like.
- ▶ Paint or colour in your picture.
- ▶ Cut along the jigsaw piece lines.
- * You can glue your picture on to cardboard first to make it stronger.

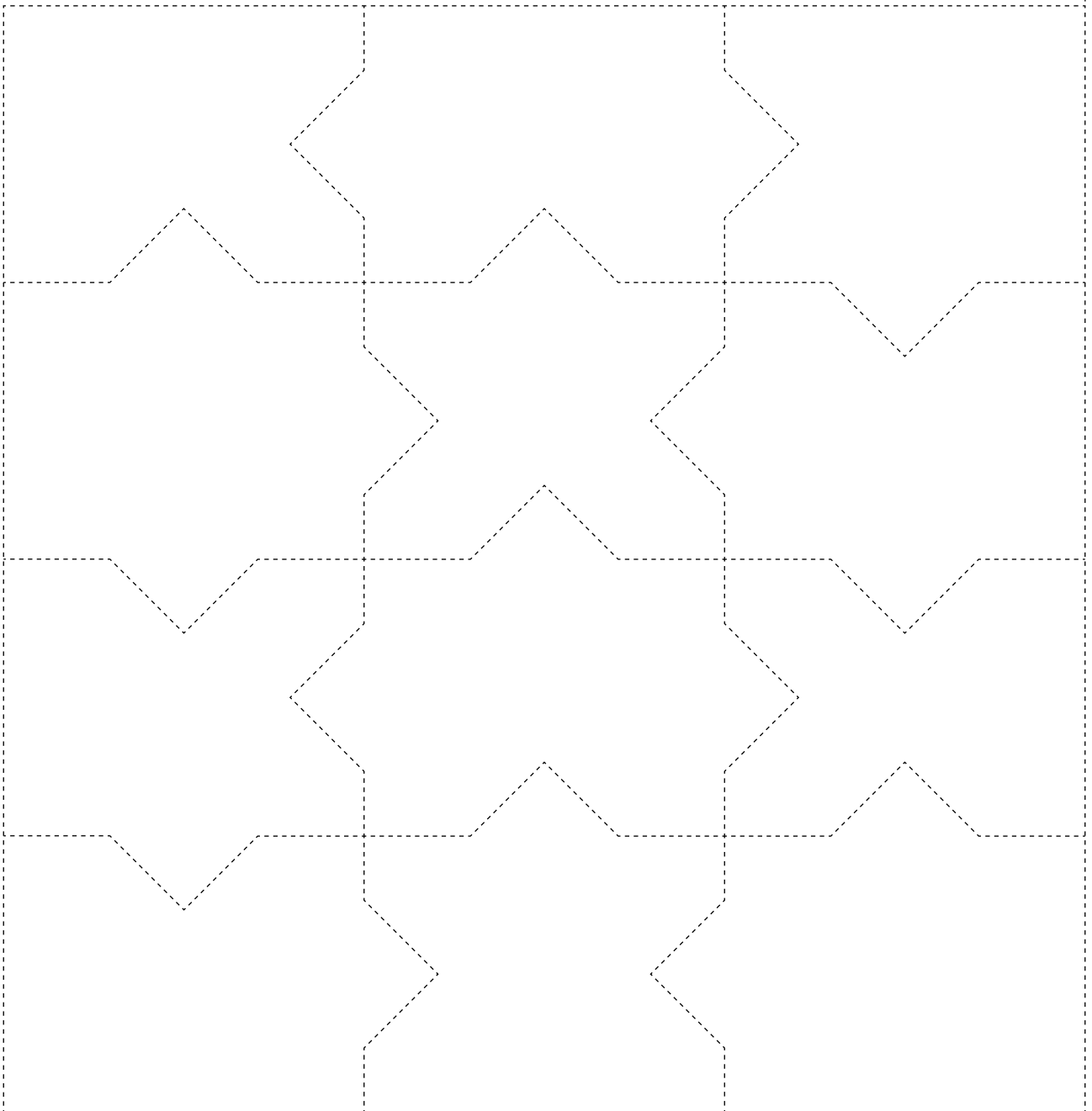

Random Acts of Kindness

Based on *Jigsaw: A Puzzle in the Post* by Bob Graham



In the book *Jigsaw: A Puzzle in the Post*, the Kelly family receive a jigsaw puzzle from an anonymous sender. Have you ever received something kind from someone you did not know? What is a random act of kindness? Have you ever given or received a random act of kindness? As a class, make a list of random acts of kindness.

If you could give something to a stranger that they would appreciate, draw (and write) what it would be on the parcel below. Write who it is to and design a stamp for it. Display them in your library or classroom in a Random Acts of Kindness display.

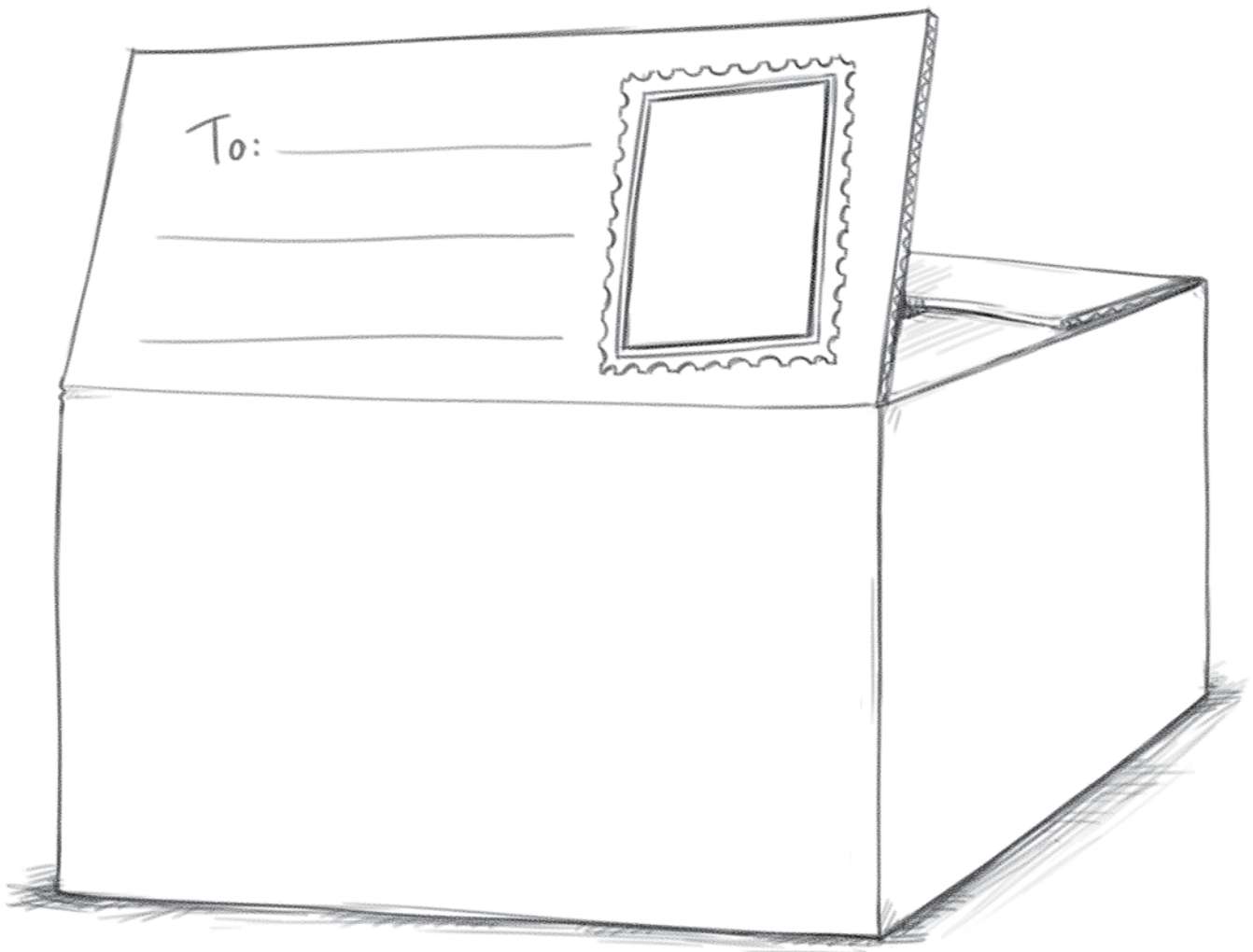

Write a kind note or card to someone. It may be for a person you don't talk to often. Tell them what you appreciate about them. Place your kind note or card somewhere they can find it, or in a class-made post box!



Challenge yourself to do random acts of kindness as often as you can!

Sound Map

Based on *Where the Lyrebird Lives* by Vikki Conley and Max Hamilton

A rainforest is full of many magical sounds. Use the sounds the family heard while searching for the lyrebird to create a sound map. Draw a picture to match each sound.

What sounds did you hear?

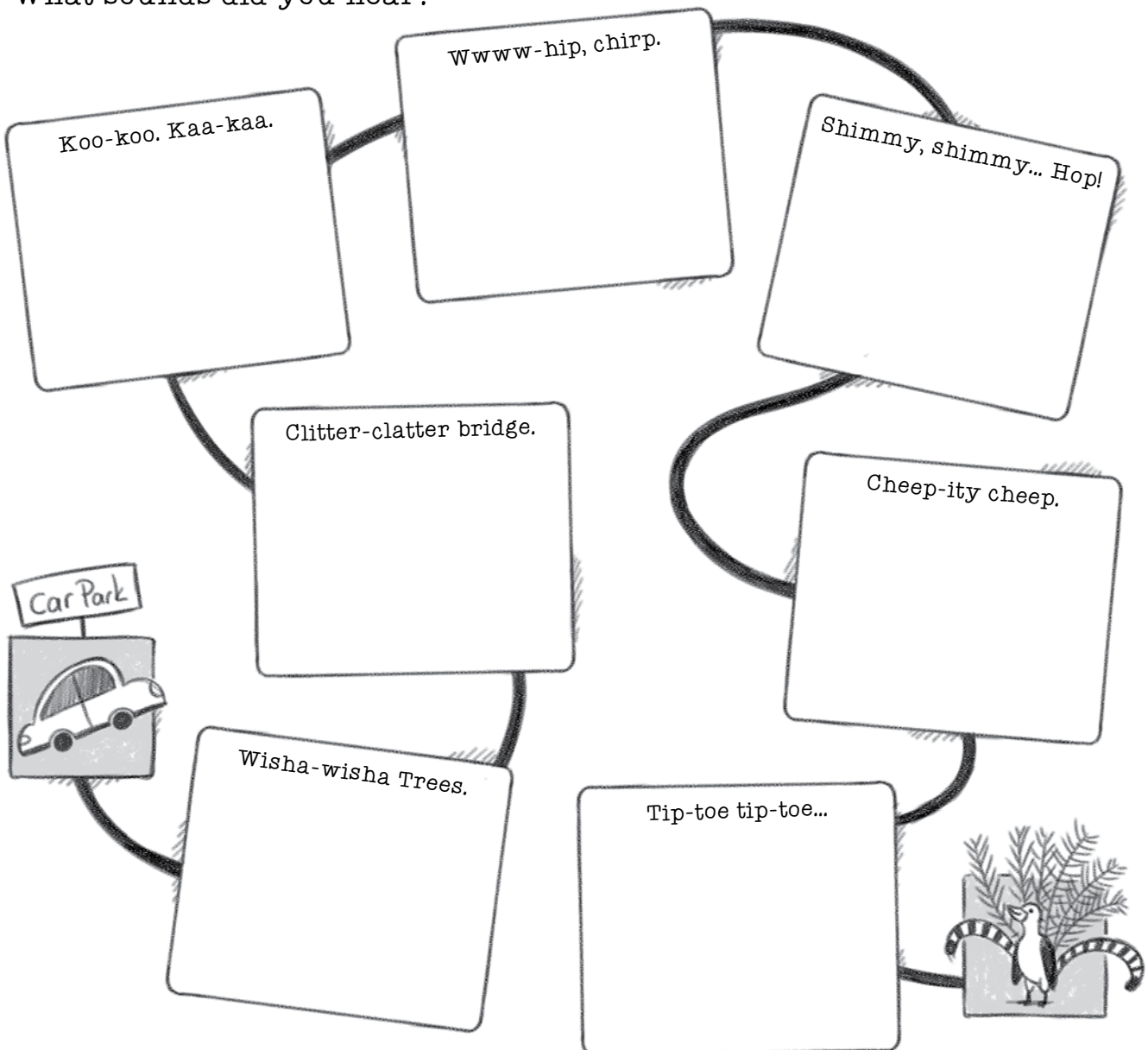

Vikki Conley uses **alliteration** and **onomatopoeia** to bring the sounds of the rainforest alive.

Alliteration is the repetition of the initial consonant sound of nearby words to inject mood or emotion into writing. **Onomatopoeia** is the use or creation of a word that imitates or suggests the sound it is describing.

Think about the sounds you hear around your school. Can you make a sound map to guide someone on a journey through your school?

Rhyme Time

Based on **Snap!** by Anna Walker

Did you know the green tree frog has four fingers and five toes, all with flat discs to help them climb? They are nocturnal and eat insects and other small creatures. What else do you know about these frogs?

Underneath each word, make a list of other words that rhyme.

drop	fish	snap	snip	bump

Find the frog by joining up the letters.

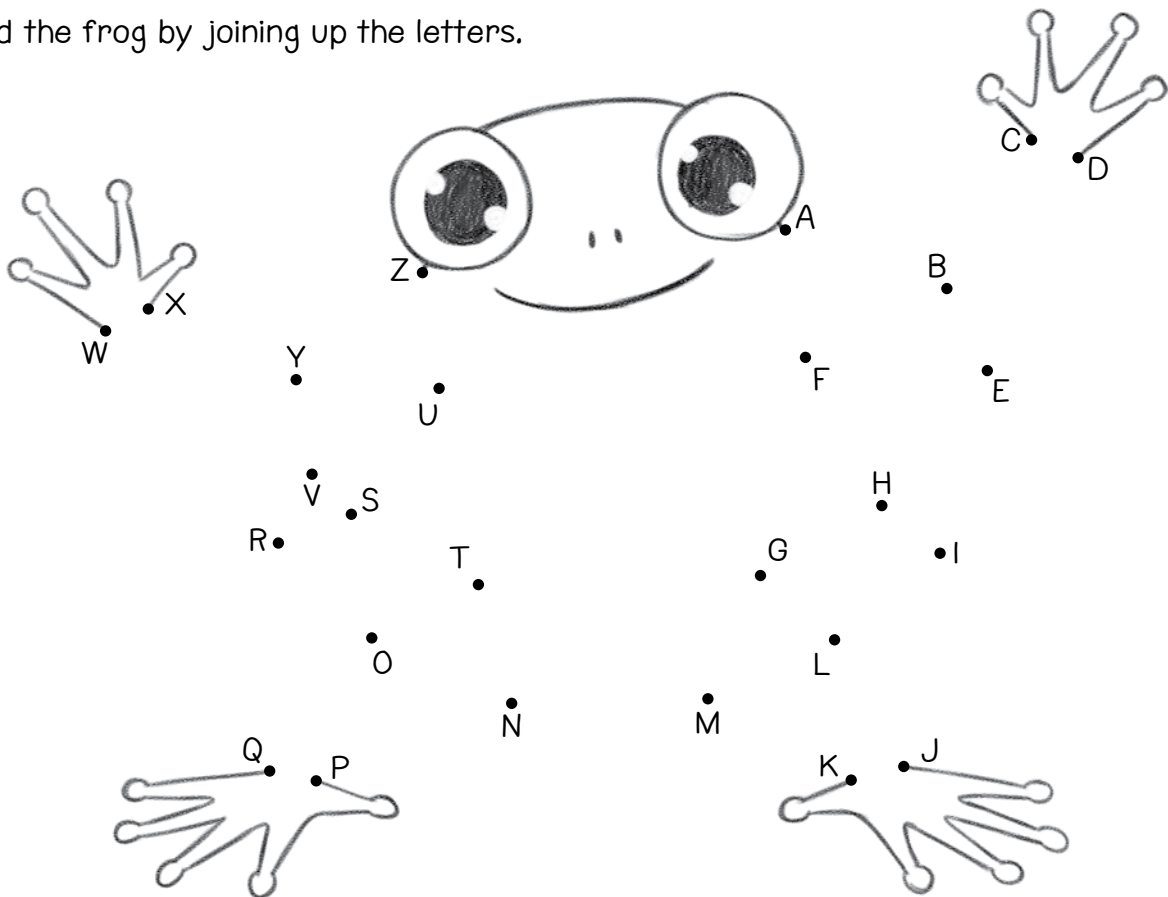

Ant City Maze

Based on **Naturopolis** by Deborah Frenkel and Ingrid Bartkowiak

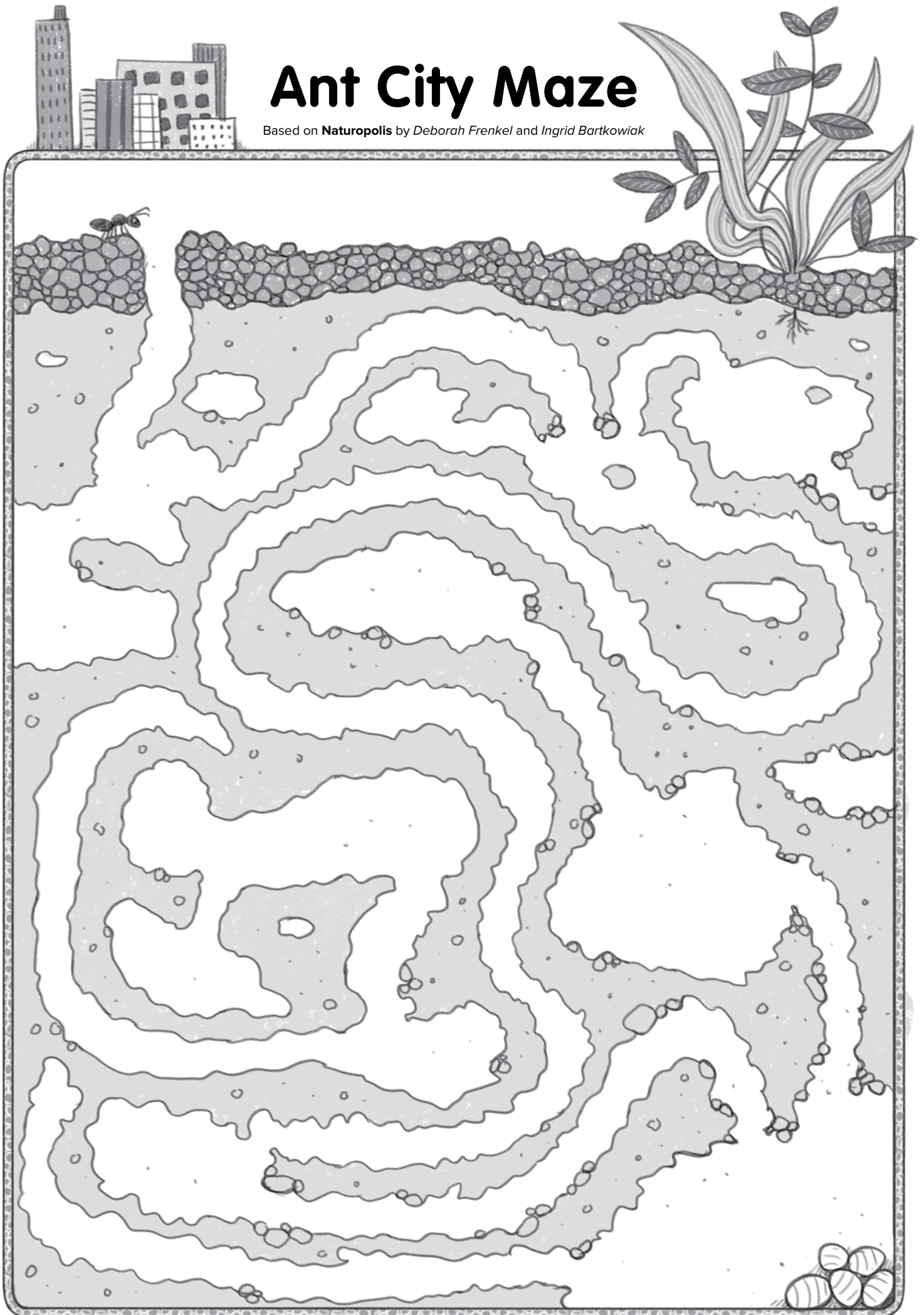



What Dogs See

Based on *The Way of Dog* by Zana Fraillon and Sean Buckingham



Dogs often seem confused about many human activities or objects in their environment. In this book, Scruffity has unusual names for things that humans take for granted. For example: he calls humans **'shoe-legs'**, a train a **'snaking metal muncher'** and birds **'sky singers.'**

Try to see the following things as a dog might see them and give them new names from a dog's perspective.

Car	TV	Fan
Air conditioner	Washing machine	Ringling phone
Electric pole	Door bell	Fridge

Pick your favourite three and draw pictures in the boxes below of what you think a dog sees.

--	--	--

Particular Penguins

Based on **Frank's Red Hat** by Sean E Avery

Frank and his penguin friends have very expressive eyes.
Look closely at Sean E Avery's illustrations.
Add to the eyes to show how each of the penguins below is feeling.

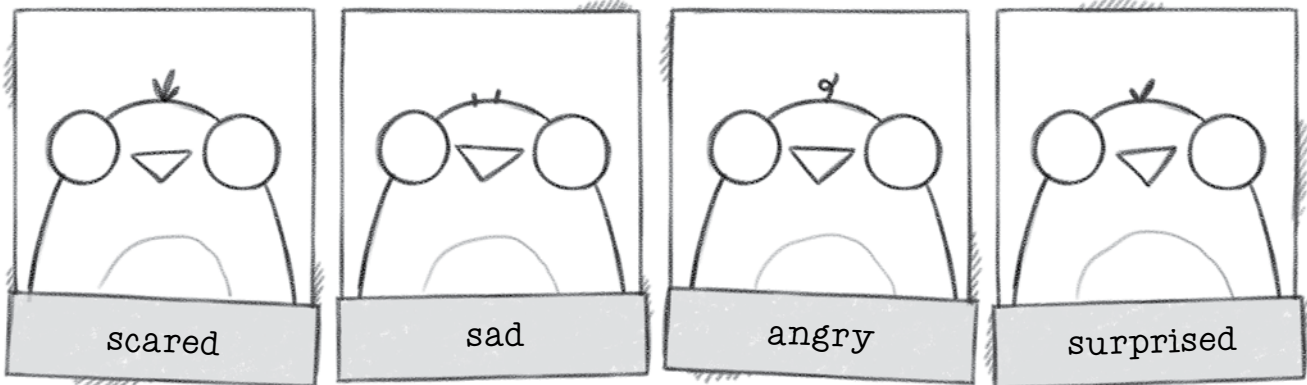

Look at the hat designs on the end papers. Create an exciting new hat for Frank, using your favourite colours. You could use collage or any other medium of your choice. Once you have designed Frank's hat, make a life-size one that you can wear by using cardboard or a container as your base. Maybe you can wear it for a Book Week dress-up day!

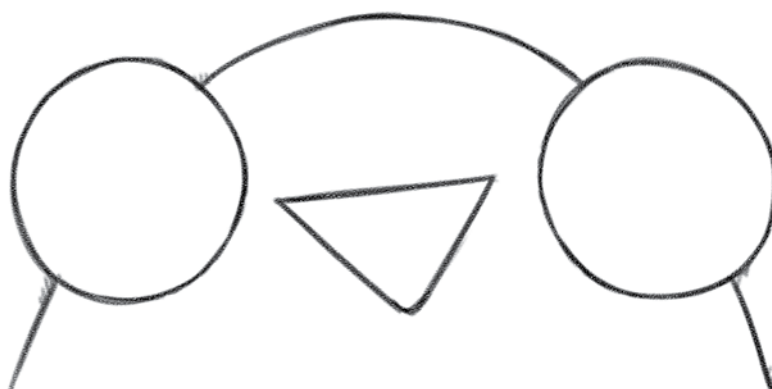



Investigating our Reefs

Based on **A Is for Australian Reefs** by Frané Lessac



Frané Lessac's fascinating new book, **A Is for Australian Reefs**, shows that along the coastline of Australia, underwater reefs are bustling with the most amazing sea creatures on the planet. Answers to Challenge and Word Search bit.ly/Aus-Reefs

Challenge: Answer the questions listed on the back of the book? Use picture clues, alphabetical order, maps or the text to find the answers.

Word Search 1: Complete the Word Search below.

Brainstorm: Think, Pair, Share to create a word list for life on Australian reefs. Use **A Is for Australian Reefs** as well as other books from your library.

Word Search 2: Using square-ruled paper, create a word search for others using your word list.

H	A	L	X	Y	R	D	E	C	N	E	F	E	D	K	J	F	M	S	Y
S	Q	U	I	L	T	B	I	O	D	I	V	E	R	S	I	T	Y	O	O
I	U	Z	O	V	P	E	W	E	A	K	I	Q	W	S	R	E	I	S	P
F	E	A	S	I	D	O	H	U	R	R	C	A	H	I	L	T	P	R	U
Y	E	L	L	O	W	T	A	I	L	B	A	R	R	A	C	U	D	A	S
L	N	I	O	L	E	A	L	W	E	C	M	B	S	M	I	N	P	T	A
L	S	A	E	E	O	L	E	L	A	M	O	B	C	V	J	S	A	S	L
E	L	Z	Q	T	R	I	S	O	F	U	U	K	S	I	N	H	R	A	N
J	A	O	P	S	X	A	H	C	Y	A	F	Y	U	T	I	E	R	E	G
R	N	E	T	E	N	R	A	Y	S	M	L	K	L	J	N	L	O	S	R
O	D	P	S	A	G	H	R	A	E	G	A	N	L	I	G	L	T	P	E
A	G	S	Z	A	S	Q	K	U	A	Y	G	I	O	L	A	G	F	E	E
E	R	N	C	P	V	Y	I	A	D	P	E	R	M	A	L	R	I	G	N
B	O	I	O	P	O	Z	E	B	R	A	S	E	A	H	O	R	S	E	T
M	U	H	E	L	M	T	C	X	A	J	I	N	D	A	O	T	H	S	U
T	P	C	W	E	O	E	A	I	G	O	P	Y	A	D	R	I	O	L	R
U	E	R	I	S	G	S	U	P	O	T	C	O	L	E	E	N	Y	P	T
I	R	U	K	A	N	D	J	I	N	E	L	W	C	B	E	V	N	T	L
P	S	G	X	A	N	T	H	I	D	C	R	A	B	S	F	L	I	A	E
S	W	T	P	T	W	I	H	S	I	F	D	N	A	H	P	Y	S	F	Q

Atoll
 Biodiversity
 Camouflage
 Defence
 Eels
 Fish
 Green turtle

Handfish
 Irukandji
 Jellyfish
 Krill
 Leafy Seadragon
 Molluscs
 Ningaloo Reef

Octopus
 Parrotfish
 Yellowtail
 Queensland groupers
 Rays
 Sea Stars
 Tun Shell

Urchins
 Violet Sea Apples
 Whale Shark
 Xanthid Crabs
 Barracudas
 Zebra Sea Horse